

20th June'2014

Dear Jennifer

Submitting the following information in order to complete our request :

1. Has groundwater level been determined in order to insure that soak pits end at least 1.5-2m above groundwater level?

Ans : The Soak Pits will be constructed in ponds to recharge the collected rain water. We have experience in Soak Pits under expert advice. NOTE : RC Central Calcutta has completed two M/G Projects # 73829 & 74380. Please refer Reports submitted to TRF.

2. Is area where soak pits will be located at risk of flooding?

Ans : We need the ponds to be flooded & filled with the Rain water for the Soak Pits to be effective. Excessive rain causing FLOODING is NOT a concern to the Soak Pits.

3. Is the ground/soil where the soak pits will be located predominantly clay, hard packed or rocky soil?

Ans : The soil is predominantly Clay with under ground strata's of sand layers.

4. Will soak pits be kept at least 30m from any possible water well location?

Ans : This is an irrelevant question ... The Soak Pits are planned to be within water bodies.

5. a) Will the toilets be installed in individual villager's homes?

Ans : Yes

b)How will hand washing supplies be provided for?

Ans : The project provides for Tubewells. Beneficiaries to buy soap or use ash.

c) Do the villagers have the funds to maintain and repair the toilets?

Ans : Yes

d) Will there be any monitoring of how successfully these toilets are maintained and utilized?

Ans : Yes .. RCC Members are already educated to monitor

6. In the past, naturally-occurring arsenic contaminated water was detected in eastern parts of India & Bangladesh. Therefore, to help ensure the safety of the beneficiaries, please submit a plan to ensure continued monitoring of arsenic contamination in the wells after project completion.

Ans : The District of Hooghly is NOT affected by arsenic. However, as abundant caution the water of tubewells would be tested before use.

7. a) Where will the tube wells be located?

Ans : The tubewells would be located at least 200 meters apart.

b) How were the locations identified?

Ans : By visits of Rotarains to the village and the involvement of the RCC Members & beneficiaries.

c) Who owns the land on which the wells will be drilled?

Ans : Beneficiary.

d) How will the water be accessed by the villagers?

Ans : Each Tubewell will have a hand pump and cater to about 60 families.

8. a) Please provide more information about the working team that will monitor the outcomes and maintenance of the tube wells.

Ans : The working Team will be three members of RCC Dakshindihi.

b) How much is the monthly fee that the group will collect per family for maintenance of the wells?

Ans : Approx 60 Families are expected to use a Tubewell. Rs 5/- per family every month.

c) How will the finances be handled?

Ans : RCC Dakshindihi will handle the funds

d) Please indicate how have the community members indicated their willingness to pay the monthly fee.

Ans : Nearly all families are willing to pay.

9. a) The training components of the project are essential for sustainable outcomes.

More detail in the description of the hygiene education training being provided is needed. Please provide a more detailed description of what type of training the project will provide that includes the training topics or curriculum, who will provide the trainings and who will receive the trainings and the frequency of the training during the lifecycle of the grant.

Ans : **A curriculum of ; water, sanitation, and/or hygiene training topics will be covered.** The training programs and advocacy are meant to create awareness, generate demand and change attitudes and behavior among the rural masses about Sanitation, Toilets Etiquettes and Unsafe drinking water and its effect on their health.

b) How will individuals be selected from the community to participate in these trainings?

Ans : Through this program we would create awareness among School Children & beneficiary Families about Sanitation, Hand Wash and Safe Drinking Water.

10. Do you intend on providing technical training on the maintenance, repair and governance for the community to support the infrastructure (soak pits, latrines and tube wells) you proposed to install in this project? The training components of the project are essential for sustainable outcomes. More detail in the description of the training being provided is needed. Please provide a more detailed description of what type of training the project will provide that includes the training topics or curriculum, who will provide the trainings and who will receive the trainings and the frequency of the training during the lifecycle of the grant. How will individuals be selected from the community to participate in these trainings?

Ans : Rotary Club has identified J Stone & Co. who have agreed to provide Training Experts. The curriculum would cover –

- Importance of health and hygiene
- Importance of healthcare to national productivity
- Relevance of proper sanitation
- Perils of Open Defecation
- Prevention of Water Borne Diseases
- Importance of Water Conservation

The Training would take place in Schools who have agreed. The training will be for both Children & beneficiaries (specially women) selected from beneficiary families.

11. The "Survey Form on Eye" was uploaded to this application, please explain in what context the Survey Form on Eye is being used in this project? Is the Human Development Centre involved in this project ?

Ans : We propose to replicate the re-design the survey Form. Human Development Centre is NOT involved in the project.

12. a) Please provide more information about the community assessment that was performed to determine the need of this particular village. Who in the community was consulted?

Ans : The village Belpara is a part of RCC Dakshindihi sponsored by the Rotary Club in the year 1994. Rotarians have been visiting the village regularly. Rotary Club through several TRF Grants have already constructed & are in use over 300 Toilets, 20 tubewells & 150 Soak Pits. All these have uplifted & benefitted the villagers.

b) How exactly were the needs of this particular community identified?

Ans : By visits of Rotarians and past experience.

13. a) How were members of the local community involved in planning the proposed project?

Ans : Rotarians with the active involvement of RCC members & beneficiaries of Vill : Belpara planned the project.

b) The applicants provided information on the activities that the community participated in the past but did not address how community members were involved in the planning of this project. How did they decide tube wells, toilets, and soak pits were the best solutions for their community?

Ans : The project has an integrated approach on Health & Hygiene. Only Clean drinking water does NOT solve the problem. Moreover the Underground water table has been seen to drop rapidly & thus it is the past experience that it is necessary to collect rainwater and re-charge the same into the underground drying sand strata for being available specially during the dry season.

c) How did they decide upon the best way to financially manage the implemented infrastructure?

Ans : Past experience. Meeting with the RCC Members & Beneficiaries.

14. Please describe the type of latrine and sewage management system that the community selected during your community assessment.

Ans : The Toilets are UNICEF Design single deep pit toilets. (attached 'A')

15. Please provide an MOU (template provide below) with RCC Dakshindihi, be sure to clearly indicate who will be taking responsibility for managing the installation of the infrastructure as well as all other aspects of the project implementation.

Ans : Please approve - Draft attached 'B'

16. Please define "Experts Honorarium" in the budget.

Ans : The Honorarium to be paid to the experts for :

- Overseeing the construction of Soak Pits in ponds
- Training of School Children & Beneficiary families as indicated above.

17. There is currently no budget item to account for the training proposed in your application. Please describe how you will account for these costs in your budget.

Ans : This is included in the Expert Honorarium as explained above.

Please note that for the Foundation's measurement purposes, this grant is considered primarily a WASH area of focus grant and so we have removed the measurements from the DPT secondary area of focus. You will not be required to report any measurements on DPT.

Ans : NOTED

Annexure - 'A'

Toilet design -

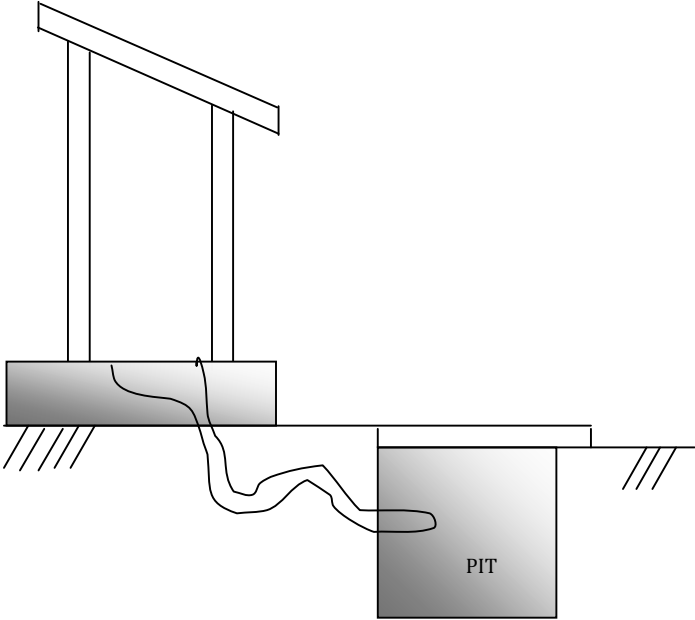
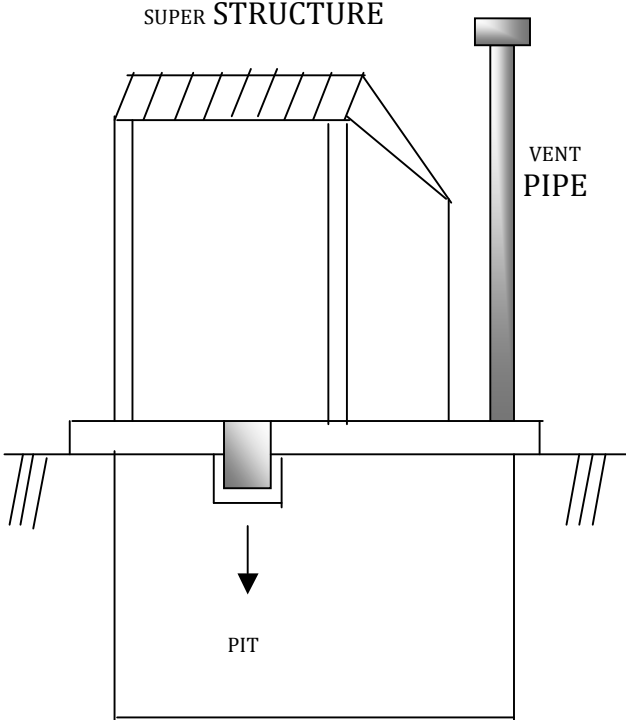

MEMORANDUM OF UNDERSTANDING

between
Rotary Club of Central Calcutta
and
Rotary Club of Hurst-Euless-Bedford
and
RCC Dakshindihi

1. Subject

Global Grant # 1411535 in Village : Belpara, Dist : Hoogly, West Bengal, India

2. Purpose

This document serves to establish a framework of cooperation and agreement between the aforementioned parties as it pertains to the implementation of a project financed by a Rotary Foundation Global Grant.

3. Primary Contacts

	[HOST PARTNER]	[INTL PARTNER]	[COOP ORG]
NAME	BINOD KHAITAN	GARY SHORT	Md WALLUDIN
ADDRESS	5, QUEEN’S PARK KOLKATA – 700 019, INDIA	3901 HILLWOOD WAY TEXAS, BEDFORD WAY, USA	C/O BRIGHT ACADEMY RAMAPARA, HOOGHY
PHONE	+91 96747 45001	+1 817 980 2464	+91 97328 60273
E-MAIL	binodkay@yahoo.com	garyshort@gmail.com	N A

4. Understandings

- A. All parties affirm that Global Grant # 1411535 is initiated, controlled, and managed by the Rotary clubs and/or districts involved in the project.
- B. RC CENTRAL CALCUTTA and RC HURST-EULESS-BDFORD affirm that RCC DAKSHINDIHI is reputable and responsible and acts within all governing laws of the project country.
- C. All parties acknowledge that Global Grant # 1411535, if approved, will be awarded to RC Central Calcutta and RC Hurst-Euless-Bedford and not to RCC Dakshindihi.
- D. All project funds will be in the custody of the partner Rotarians and will not be managed by RCC Dakshindihi.
- E. RCC Dakshindihi must abide by The Rotary Foundation grant terms and conditions.
- F. RCC Dakshindihi and its involvement in this project may be subject to financial and operational review/audit by The Rotary Foundation.

5. RC Central Calcutta shall:

- 1. Print suitable material for display & distribution
- 2. Make payments (to be negotiated) for Workshops & Seminars with Experts
- 3. Co-ordinate with RCC to organize Workshops & interviews.
- 4. Co-ordinate, supervise & select suitable contractors.

5. Keep in contact with International Rotary Club Sponsors.
6. Take Visiting Rotarians to Project Site
7. Treat Grant fund as sacred to be handled with utmost Stewardship.
8. Report to The Rotary Foundation on implementation of project

6. RC Hurst-Eules-Bedford shall:

1. Try & visit the project sites, if possible whenever in India.
2. Monitor the project by asking for updates from Host Club.
3. Keep regular touch via email.
- 4 Publicize the project at Rotary events, through publications & media.

7. RCC Dakshindihi shall:

1. Coordinate with the Beneficiaries to -
 - Attend meeting & Training Workshops
 - Provided unskilled labor for the construction of toilets & Soak Pits
 - Use the tube wells and toilets and learn to maintain them & keep proper hygienic conditions.
 - Spread the word to the neighboring villages to encourage healthy living.
 - Provide ponds for collection of rain water and install Soak Pits for recharge UG Water.
2. Oversee the work of contractors and report to RC Central Calcutta.
3. Monitor the usage & maintenance of Toilets, Tubwells & Soak Pits
4. Collect, monitor & maintain accounts of collections from beneficiary family.

8. Modification

Modifications within the scope of the instrument shall be made by mutual consent of the parties, by the issuance of a written modification, signed and dated by all parties, and approved by The Rotary Foundation prior to any changes being performed.

9. Conflict of Interest

Any real or perceived conflicts of interest must be disclosed to The Rotary Foundation, including any Rotarians serving as paid staff or board of directors for the cooperating organization.

10. Signatures

By signing below, the aforementioned parties agree to the terms of this memorandum of understanding.

RC Central Calcutta DATE

RC Hurst-Eules-Bedford DATE

RCC Dakshindihi DATE